

**DESCRIPTION**

**APPLICATIONS:** For use in measurement of potable cold water in commercial and industrial services where flow is in one direction.

**OPERATION:** Water flows into the meter's measuring element contacting the multi-vaned rotor. Flow readings are obtained by rotor revolutions transmitted by magnetic drive coupling through the meter's cover plate to the sealed register. Magnetic drive is achieved by a right angle worm drive, coupling the rotor to the vertical transmission spindle, driving a gear set rotating the magnet carrier. A ceramic magnet in a carrier rotates around the vertical axis. Rotor rotation is transmitted to the register gearing through this magnetic coupling.

The turbo measuring element is designed to greatly reduce wear by reducing friction potential between the moving parts of the rotor and bearing system. Less wear, in this critical area of the design, provides the utility manager with a lower life cycle cost for meter application. Throughout the normal operating range of the meter, the rotor floats between the bearing system.

**OPERATING PERFORMANCE:** The Badger® Recordall Turbo 6200 meter meets and exceeds registration accuracy for the low, normal, and maximum continuous operation flow rates as stated in AWWA Standard C701.

**CONSTRUCTION:** The Badger Recordall Turbo 6200 meter construction, which complies with ANSI and AWWA C701 standards, consists of three basic components: meter housing, interchangeable measuring element and permanently sealed register. The housing is cast iron with round flanges. The measuring element consists of the transmission coupling, measuring element insert, rotor, inlet and outlet straightening vanes/nose cones and calibration ring assembly. The unique inlet and outlet straightening vanes minimize swirl from piping arrangements upstream.

To simplify maintenance, the register and measuring element can be removed without removing the meter housing from the installation. No change gears are required for accuracy calibration. Interchangeability of certain parts between 8", 10", and 12" meters also minimizes spare parts inventory investment.

**MAGNETIC DRIVE:** Direct magnetic drive, through the use of high-strength magnets, provides positive, reliable and dependable register coupling for straight-reading, remote or automatic meter reading options.

**SEALED REGISTER:** The standard register consists of a straight-reading odometer-type totalization display, 360° test circle with center sweep hand and flow finder to detect leaks. Register gearing consists of self-lubricating thermoplastic gears to minimize friction and provide long life. Permanently sealed; dirt, moisture, tampering and lens fogging problems are eliminated. Multi-position register simplifies meter installation and reading. Automatic meter reading and close proximity systems are available for all Recordall Turbo meters. (See back of sheet for additional information.) All reading options are removable from the meter without disrupting water service.

**TAMPER-RESISTANT FEATURES:** Customer removal of the register to obtain free water is prevented when the tamper detection seal wire screw or TORX® tamper resistant seal screw is added to the meter. Either can be installed at the meter site or at the factory. A tamper resistant calibration plug seal provides protection from unauthorized personnel.

**STRAINER:** A separate strainer is recommended to protect the measuring element.

**MAINTENANCE:** Badger Recordall Turbo meters are designed and manufactured to provide long-term service with minimal maintenance. When maintenance is required, it can be performed easily either at the meter installation or at any other convenient location. As an alternative to repair by the utility, Badger offers various maintenance and meter component exchange programs to fit the needs of the utility.



**SPECIFICATIONS**

<b>Typical Operating Range (100% ± 1.5%)</b>	90 - 8800 GPM (20.5 to 1998 m³/h)
<b>Maximum Continuous Operation</b>	6200 GPM (1408 m³/h)
<b>Maximum Intermittent Flow</b>	8800 GPM (1998 m³/h)
<b>Typical Low Flow (95%-100%)</b>	65 GPM (14.8 m³/h)
<b>Pressure Loss at Maximum Continuous Operation</b>	0.8 PSI (0.05 bar at 1408 m³/h)
<b>Maximum Operating Temperature</b>	120°F (49°C)
<b>Maximum Operating Pressure</b>	150 PSI (10 bar)
<b>Meter Flanges</b>	12" Round AWWA 125 pound class
<b>Register</b>	Straight reading, permanently sealed magnetic drive standard. Automatic Meter Reading units optional.
<b>Registration</b>	10,000,000,000 Gallons 10,000 gallons/sweep hand revolution. 1,000,000,000 Cubic Feet 1,000 cubic ft./sweep hand revolution. 10,000,000 m³ 10 m³/sweep hand revolution. 10,000,000,000 Imperial Gallons 10,000 imperial gallons/sweep hand revolution.

**MATERIALS**

<b>Housing</b>	Cast Iron
<b>Nose Cone and Straightening Vanes</b>	Thermoplastic
<b>Rotor</b>	Thermoplastic
<b>Rotor Radial Bearings</b>	Lubricated Thermoplastic
<b>Rotor Thrust Bearings</b>	Sapphire Jewels
<b>Rotor Bearing Pivots</b>	Passivated 316 Stainless Steel
<b>Calibration Mechanism</b>	Stainless Steel and Thermoplastic
<b>Magnet</b>	Ceramic
<b>Register Lid and Shroud</b>	Thermoplastic, Bronze
<b>Trim</b>	316 Stainless Steel

**CONNECTIONS:** Companion flanges for installation of meters on various pipe types and sizes are available in cast iron as an option.

### PRESSURE LOSS CHART

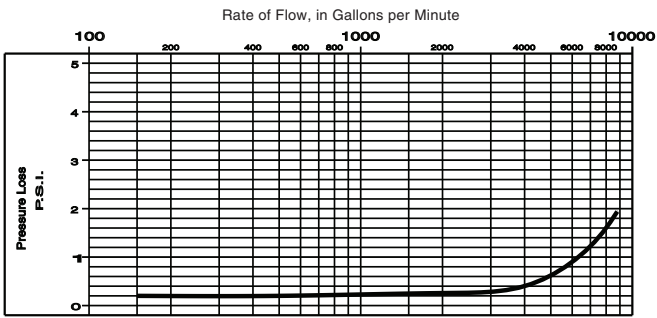

### ACCURACY CHART

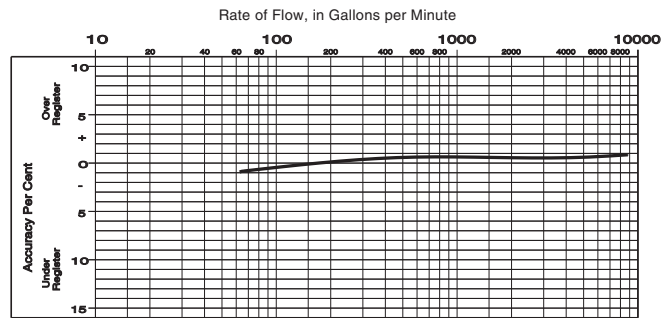

Meter & Pipe Size	DIMENSIONS								
	Length A	Width B	Height C	Flange D	Bolt Circle	Centerline F	No. Bolts	Net Weight	Shipping Weight
12" Meter (DN 300)	19 11/16" (499 mm)	19" (482 mm)	19 11/16" (500 mm)	1.26" (32 mm)	17" (432mm)	8 7/8" (226 mm)	12	262 lb. (118.8 kg)	286 lb. (129.7 kg)

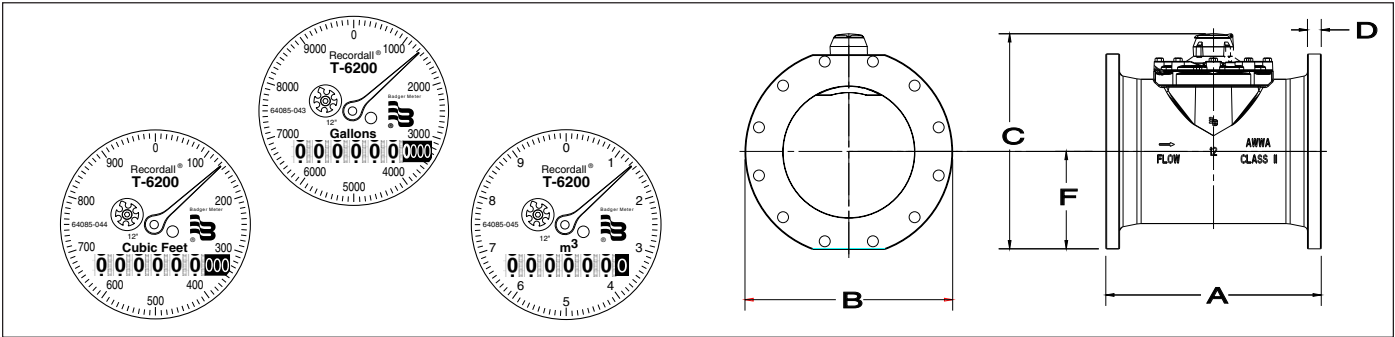

**PROPER INSTALLATION:** The following installation guidelines will insure optimum field performance and reliability when installing a Badger Turbo meter.

1. A strainer is recommended to insure optimum flow conditioning and protection for the turbo meter measuring element.
2. When using a strainer, five (5) diameters of straight pipe separating the strainer upstream of the meter is recommended.
3. ONLY full-open gate valves should be used immediately upstream of the meter. Butterfly valves MUST be five (5) pipe diameters or more upstream of the meter. Full-open gate or butterfly valves can be used downstream.
4. DO NOT install pressure reducing devices or check valves upstream of the meter.

5. Unweighted check valves MUST be located at least three (3) pipe diameters downstream of the meter.
6. Pressure reducing devices and externally weighted check valves MUST be located at least five (5) pipe diameters downstream of the meter.

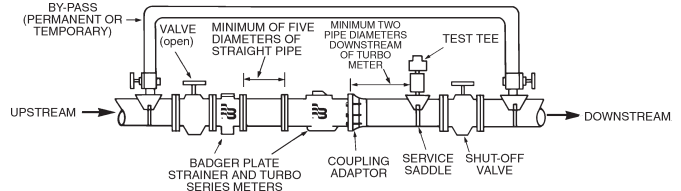

Badger® and Recordall® are registered trademarks of Badger Meter, Inc.



Please see our website at  
[www.badgermeter.com](http://www.badgermeter.com)  
 for specific contacts.

Due to continuous research, product improvements and enhancements, Badger Meter reserves the right to change product or system specifications without notice, except to the extent an outstanding contractual obligation exists.



**BadgerMeter, Inc.**

P.O. Box 245036, Milwaukee, WI 53224-9536  
 (800) 876-3837 / Fax: (888) 371-5982

[www.badgermeter.com](http://www.badgermeter.com)