

**NIAGARA<sup>®</sup>**

*Model R-25  
High Speed Pulser*

**Installation, Operation  
and Maintenance Manual**

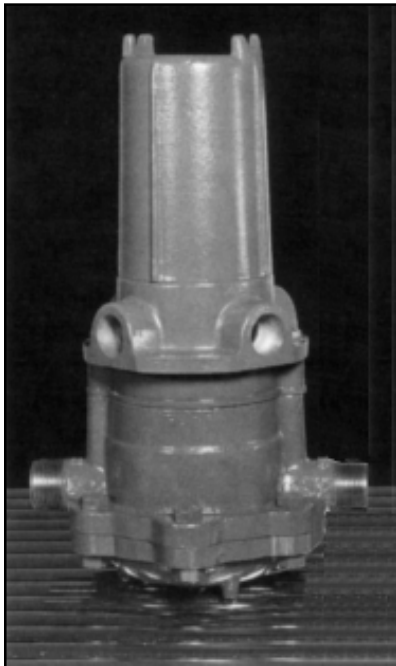

## *Table of Contents*

General .....	1
Specifications .....	1
Installation .....	2
Wiring and Terminal Connections .....	3
Testing .....	3
Start Up .....	5
Maintenance .....	6

## *Installation, Operation & Maintenance*

### **GENERAL**

The R-25 High Speed Pulser is a transmitter used to increase the pulse rate of all standard Niagara meters. The higher resolution pulse output provides faster update times for applications using flow rate indication, flow control, batch control, and BTU calculations. This is especially useful when monitoring low flow.

This universal pulser fits 3/4" to 2.5" size meters and can be retrofitted with simple hand tools. The unit is magnetically coupled to the shaft of the Niagara meter. This enables low drag sensing and allows for isolation of the electronics from the flow process. An optical encoder is used to detect shaft rotation. Electronic circuitry amplifies the signal and eliminates false signals caused by pipe vibration.

The features of the R-25 are:

- Converts mechanical meter output to electrical square-wave signals accurately.
- Produces a high speed pulse to give a higher resolution of flow measurement while maintaining accuracy.

### **SPECIFICATIONS**

**Power supply:** 12 to 24 volts  $\pm 10\%$

**Power consumption:** 375 milliwatts at 15 VDC

**Signal output:** 0 to 15 volts 70 micro seconds square pulse, nominal at 15 VDC. Open collector, internal 1/4 watt 10 K ohm pull-up resistor option is supplied. 150 mA DC maximum drive current.

**Operating temperature:**  $-32$  to  $158^{\circ}\text{F}$  (electronics)

**Process temperature:**  $-50$  to  $400^{\circ}\text{F}$  (operating fluid) **Note:** For  $250$  to  $400^{\circ}\text{F}$  a register extension is required.

**Housing:** Explosion proof type weatherproof housing with four 1/2" conduit connections; rated for Class I Group D, Class II Groups E, F, G, and Class III

**Signal wiring:** 18 awg., 3 or 4 conductor, shielded cable Belden #8770 or Alpha #5383

**Weight:** 3.3 lbs.

## **INSTALLATION**

**Caution:** Failure to follow the procedures of this manual will void the warranty of this product.

- A. Unpack and inspect for damage.
- B. Consider temperature conditions and ease of wiring when choosing a location. 15" of space above the flowmeter top is necessary.
- C. If installing a new meter complete with an R-25, follow the procedures outlined in meter manual. Wire the unit as described on page 3 of this manual.
- D. To retrofit a meter replacing a mechanical register with the R-25, see Figure 1, Meter Assembly.

When placing the R-25 on a 1" or larger meter, go to procedure F.  
If placing the R-25 on a 3/4" meter, proceed as follows:

Take the register off by removing the register mounting screws. Remove any mechanical coupling from the meter output shaft. Place spacer 1 with the threaded 5/16-18 holes on the meter and attach to the meter case by using two 10-32 x 1/2" flat head screws (supplied). Be sure countersunk mounting holes for the 10-32 screws are facing up! Place spacer 2 opposite side up on top of this one and secure using 5/16-18 screws (supplied).

Go to procedure F.

- E. For 1" meter line sizes and above, remove the register and any coupling from the output shaft. Place the spacer over the 5/16-18 mounting holes of the meter and secure in place with two 5/16-18 x 1-3/8 screws (supplied).  
Go to procedure F.

**Figure 1 — Meter Assembly**

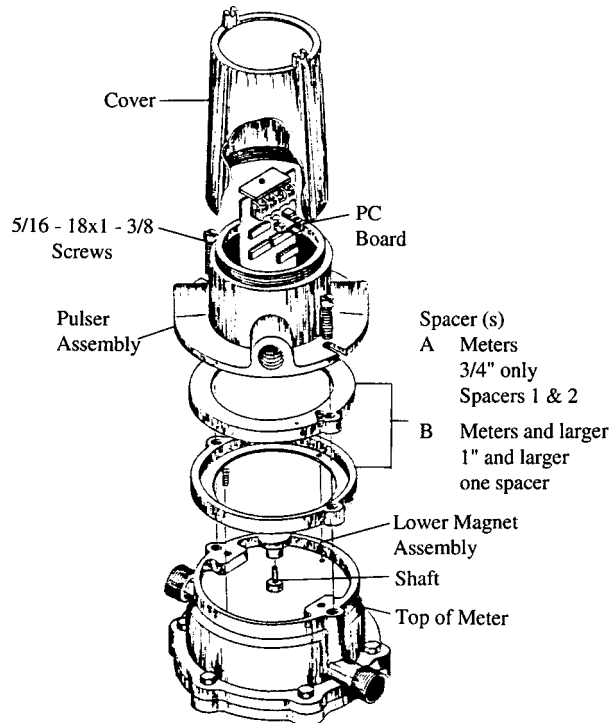

## ***Model R-25 High Speed Pulser***

F. Place the lower magnet assembly on the meter output shaft. Align the set screw of the assembly with the flat of the meter output shaft. Using a straight edge as a guide, adjust the assembly so it is approximately 1/16 to 1/8 of an inch below the top of the spacer. Tighten the set screw. Be sure the shaft is at its maximum height by gently pulling up on the magnet assembly. If the shaft does move upward slightly, but the magnet assembly remains below the top of the spacer, adjustment is acceptable at this location. If even with or above the top of the spacer, the magnet assembly will have to be lowered and the dimension rechecked for proper clearance.

**Note:** The magnet assembly should not come in contact with either the nut on the meter shaft or the R-25 enclosure when it is attached.

G. Remove the 5/16-18 screws and position the R-25 over the 5/16-18 mounting holes and secure in place using these screws.

### **Wiring and Terminal Connections**

Electrical connection cautions:

- Improper wiring may cause damage to the instrument.
- Do not exceed maximum voltage rating of 28 volts DC.
- Observe proper polarity when connecting power.
- Do not apply AC voltage to this device.
- Follow standard color codes for wire throughout the installation.
- Never route wires in the same conduit with AC power lines.
- Never route sensor wires in or around any electrical or magnetic noise producing devices, such as motors, starters, transformers, etc.
- Field splices should be either soldered or made with crimp type butt splices. Field splices should be water proof and insulated.
- Field splices should be made in junction boxes only.
- Recommended wire is 18 AWG, 3 or 4 conductor, shielded cable, provided it meets all local codes. Cable such as Belden #8770 or Alpha #5383 are recommended.
- **Never** wire unit with power on.
- Many electric components are static sensitive. Precautions should be made not to damage the unit through static discharge. Discharge body through a grounded connection before servicing.

The terminal strip is located under the R-25 cover (see Figure 2). It is made accessible by unscrewing the cover in a counter-clockwise direction.

Terminal 1 ..... – DC power (Common)  
Terminal 2 ..... + DC power  
Terminal 3 ..... – Signal (Common)  
Terminal 4 ..... + Signal

If using a Niagara signal conditioner such as a Model 1030F, follow the instructions for that device when connecting the R-25. Example: a hook up may look like this:

<b>R-25</b>	<b>Model 1030F</b>
T1 _____	Common $\perp$
T2 _____	+24 V output
T3 _____	No connection
T4 _____	Input A

**Note:** 1030F input speed must be set at 7500 Hz.

If using a device not supplied by Niagara, the input to that device must meet the following specifications:

**Output specifications:** 70  $\mu$ sec. Square-wave. Open collector: 0 to the supplied voltage, nominally. Varies according to selected power voltage supplied to the unit if using internal 10 K ohm pull-up resistor.

**Power connections:** 12 to 24 VDC  $\pm 10\%$

**Caution:** Under no circumstances should AC voltage be applied or the DC limits be exceeded.

**Testing**

The electronics portion of the R-25 has been factory tested and should require no further adjustments.

New model R-25 with meters have been calibrated and factory tested. A K-factor is supplied to the customer with the meter for determining the exact pulses per volume. The meter is calibrated to be within  $\pm 1.5\%$  of the K-factor. If supplied with a Hersey Measurement signal conditioner, the units have been precalibrated and require no further adjustments.

When an R-25 is sold to be installed on a previously shipped, shaft-driven Niagara meter, it may be necessary to move the jumpers in order to match the direction of the meter's output shaft. If no output occurs after applying flow through the meter, remove power and change the direction of the shaft rotation jumpers on the circuit board 90 degrees. See Figure 2 for location of the jumpers.

A calculation procedure (see Figure 3) is supplied to the customer to establish his K-factor based on his particular flowmeter. The chart has been calculated based on ideal conditions. The ideal number of pulses per gallon was determined using the ideal volume of fluid displaced through one complete meter revolution.

**Figure 2**

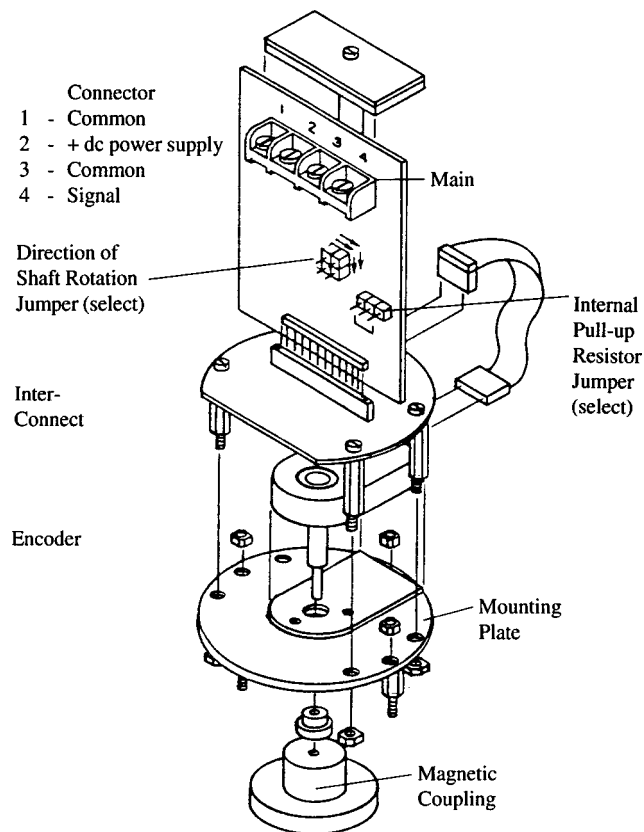

## Model R-25 High Speed Pulser

**Figure 3.** From the chart below, select meter size, range, and K-factor.

**Note:** These K-factors are calculated for ideal conditions. Wear of any parts cannot be anticipated. For critical applications, the meter should be recalibrated to establish an exact K-factor for that meter.

Size	GPM	Ratio	K-Factor Pulses/Gallon
3/4"	.5-5	256:1	459
		64:1	1836
1"	1-20	125:1	692
		25:1	3463
		5:1	17316
1-1/4"	2-30	125:1	347
		25:1	1735
		5:1	8676
1-1/2"	3-50	125:1	173
		25:1	869
		5:1	4347
2"	5-100	125:1	78
		25:1	391
		5:1	1953
2-1/2"	8-160	125:1	42
		25:1	212
		5:1	1063

For example, a 1" meter with a 125:1 gear reduction has an ideal displacement of 2.887 gallons per shaft revolution. The exact displacement can vary from the ideal due to differences in manufacturing tolerances. The encoder produces 2000 pulses per revolution. 2000 divided by the number of gallons per revolution equals the number of pulses per gallon.

$$\frac{2000}{\text{gallons per shaft revolution}} = \text{pulses per gallon}$$

**Note:** If accuracy is critical, the customer will have to calibrate his meter as described in Figure 3 or send the meter back to the factory for calibration.

If desired, a 10 K ohm pull-up resistor is supplied in the open collector circuit and may be utilized by simply moving a jumper. See Figure 2 for layout.

### Start Up

Follow the start up instructions for the Niagara meter. After the installation is complete and it has been verified, check the operation by performing the following procedure.

1. Be sure the power is within the specified limits.
2. Apply power.
3. Start flow. The R-25 should produce pulses nominally from 0 to 15 volts or the supply voltage if the open collector configuration is being used.

If the unit fails to perform:

1. Check the jumpers for rotational direction.
2. See if the pull-up resistor jumper is in the correct position, provided the option is being utilized.

3. Test power and polarity. An internal protection for reverse power is incorporated in the unit.

4. If problems still exist, consult factory.

If you need to establish your meter's K-factor:

To determine the meter's K-factor in the field, the number of pulses produced for a measured volume of fluid passing through the meter will have to be determined. A rate of flow somewhere around mid-range should provide the best accuracy.

To obtain a K-factor, divide the number of pulses accumulated by an accurately measured volume, such as gallons.

For example, it has been determined that 500 gallons have passed through the meter and the number of pulses accumulated are 346,000.

Therefore, 346,000 divided by 500 692 pulses per gallon.

$$\frac{\text{\# of pulses}}{\text{measured \# of gallons}} = \text{pulses per gallon}$$

**Note:** A totalizer count capable of measuring 10 microsecond pulses should be connected to pulser terminals 1 and 4 for measuring the accumulated number of pulses during the test.

If you wish to obtain gallons, divide the number of pulses by the K-factor. If units of measure other than gallons are desired, multiply by the appropriate correction factor for converting to those units.

## ***MAINTENANCE***

After installation and start up, the R-25 requires no maintenance.



150 Venture Boulevard  
Spartanburg, SC 29306

Phone: (800) 778-9251, (864) 574-3327

Fax: (864) 574-8063

Internet: [www.aaliant.com](http://www.aaliant.com)

E-mail: [sales@aaliant.com](mailto:sales@aaliant.com)